

LOC	QTY	REV	DESCRIPTION	DATE	APPD
G	14				
			REVISED PER 0720-0230-93	2/28/94	JAM

METPRIO
DIMENSIONS LISTED IN MM [INCHES]

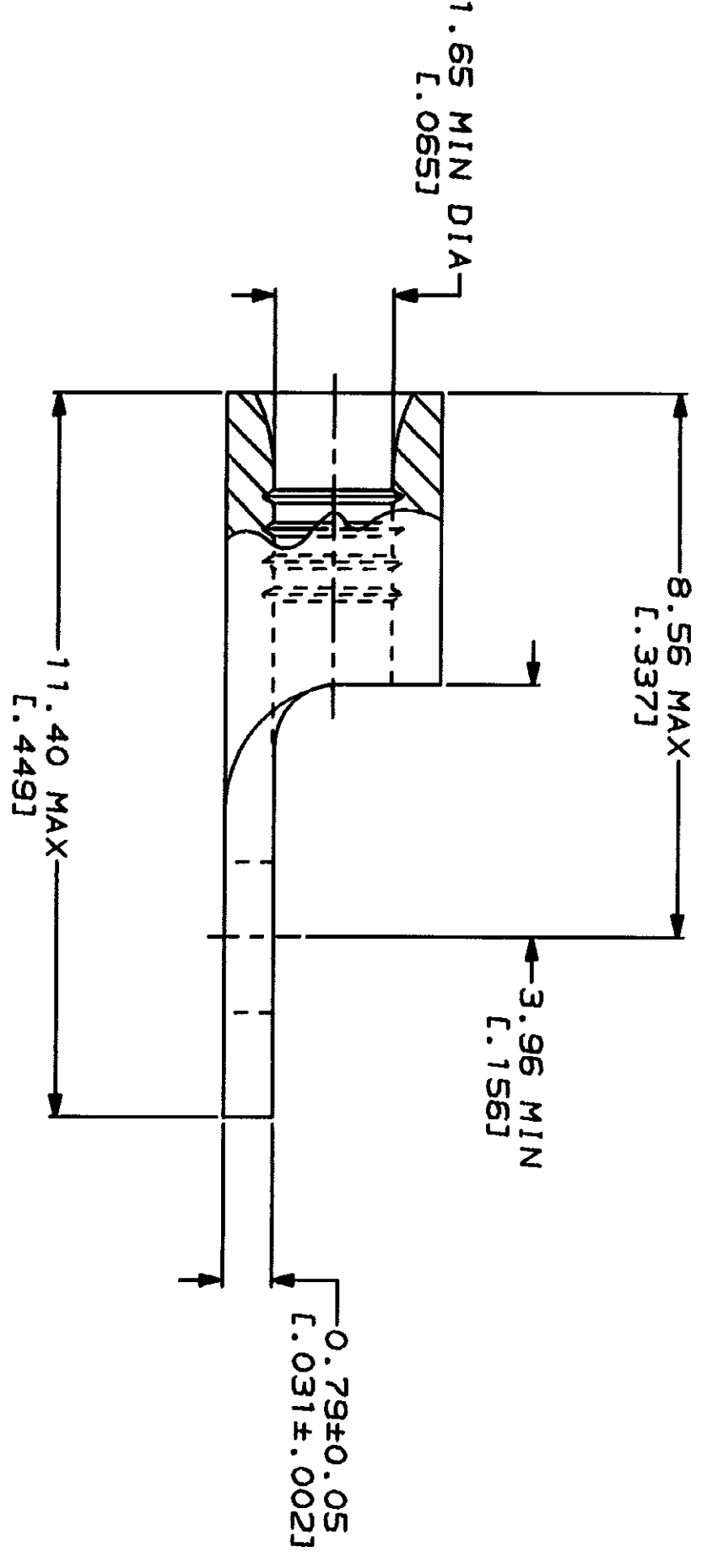
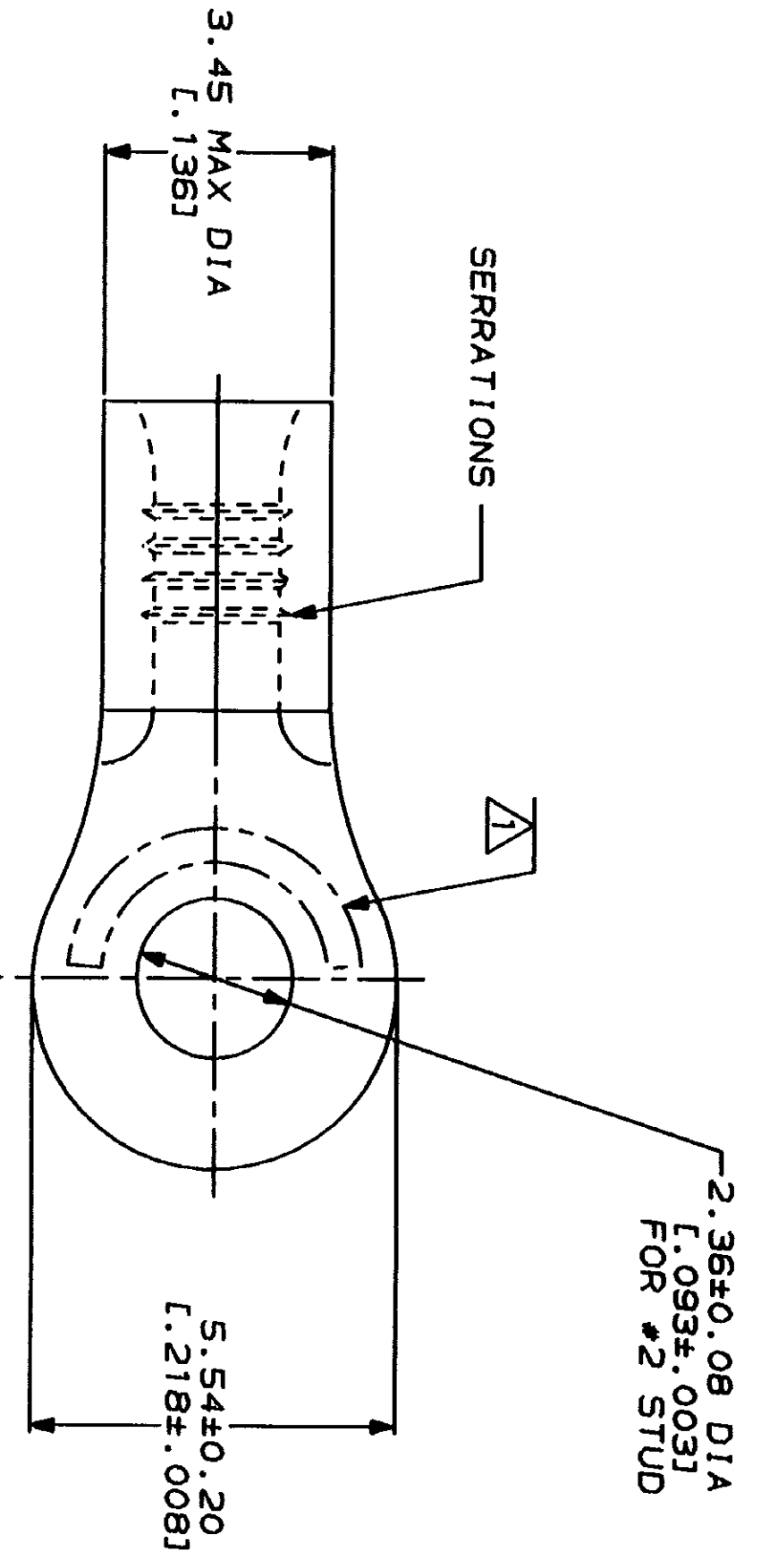

AMP WIRE RANGE 22-16 AWG STRANDED	UL E13288 Listed
• LR7189 Certified	MILITARY P/N AND CLASS
NOT CERTIFIED	NOT APPLICABLE

△ STAMP AMP 22-18* APPROX AS SHOWN
22-16 TERMINALS ARE STAMPED 22-18 IN
ACCORDANCE WITH MILITARY SPECIFICATION
MIL-T-7928, COMMERCIAL WIRE RANGE IS 22-16

AMP INCORPORATED CUSTOMER SERVICE SYSTEMS		MAX RECOMMENDED OPERATING TEMPERATURE: 170°C MAX
FOR ADDITIONAL PRODUCT INFORMATION OR COPIES OF DRAWINGS AND TECHNICAL DOCUMENTS	PRODUCT INFORMATION CENTER 1-800-522-6752	VOLTAGE RATING: NOT APPLICABLE
FOR APPLICATION TOOLING INFORMATION	TOOLING ASSISTANCE CENTER 1-800-722-1111	WIRE CROSS SECTIONAL AREA RANGE: 0.26-1.65mm ² [509-3,260] CIR MILS STRANDED
FOR ORDER ENTRY	1-800-526-5142	THIS DRAWING IS A CONTROLLED DOCUMENT FOR MILITARY USE. IT IS THE PROPERTY OF AMP AND THE COMPANY HAS THE RIGHT TO REVOKE THIS DRAWING FOR ANY REASON WITHOUT NOTICE.

DO NOT SCALE PRINT. UNLESS SPECIFIED DIMENSIONS IN MILLIMETERS TOLERANCES ON: 2 PLG DEC ± .1 3 PLG DEC ± .1 ANGLES ± .1	DR 1-27-83 TA BRINKMAN	AMP AMP Incorporated Harrisburg, PA 17105-3608 TERMINAL, RING TONGUE, BUDGET
MATERIAL COPPER PER ASTM B-152 ANNEALED	CHK 1-27-83 DA PATTERSON	
FINISH TIN PLATE 0.00254L.0001001 MIN THK PER MIL-T-10727	APPD 1-27-83 DE MILLER	
APPLICATION SPEC	APPD 1-27-83 JL HECKLEY	NAME
WEIGHT		SIZE
		CAGE CODE
		00779
		DRAWING NO
		31088
		SCALE
		10:1
		SHEET
		1 OF 1

31088
PART NO

CUSTOMER DRAWING